

FabiATech Corporation

IPC Solution

Website: <http://www.fabiatech.com>

Email: support@fabiatech.com

FB2510 All-In-One Low Power PC/104 Geode CPU Board User's Manual

JUNE 2003
Version: 1.8
Part Number: FB2510

Copyright

©Copyright 2001 FablATech Corporation, The content of this publication may not be reproduced in any part or as a whole, transcribed, stored in a retrieval system, translated into any language, or transcribed in any form or by any means, electronic, mechanical, and magnetic... or otherwise without the prior written permission of FablATech Corporation.

Disclaimer

FablATech makes no representation of warranties with respect to the contents of this publication. In an effort to continuously improve the product and add features, FablATech reserves the right to revise the publication or change specifications contained in it from time to time without prior notice of any kind from time to time.

FablATech shall not be reliable for technical or editorial errors or omissions, which may occur in this document. FablATech shall not be reliable for any indirect, special, incidental or consequential damages resulting from the furnishing, performance, or use of this document.

Trademarks

Trademarks, brand names and products names mentioned in this publication are used for identification purpose only and are the properties of their respective owners.

Technical Support

If you have problems or difficulties in using the system board, or setting up the relevant devices, and software that are not explained in this manual, please contact our service engineer for service, or send email to support@fabiatech.com.

Returning Your Board For Service & Technical Support

If your board requires servicing, contact the dealer from whom you purchased the product for service information. You can help assure efficient servicing of your product by following these guidelines:

- ❑ A list of your name, address, telephone, facsimile number, or email address where you may be reached during the day
- ❑ Description of you peripheral attachments
- ❑ Description of your software (operating system, version, application software, etc.) and BIOS configuration
- ❑ Description of the symptoms (Extract wording any message)

For updated BIOS, drivers, manuals, or product information, please visit us at www.fabiatech.com

Table of Contents

FB2510 All-In-One Low Power PC/104Geode CPU Board User's Manual	i
Chapter 1 Introducing the FB2510 System Board	1
Overview.....	1
Series Comparison Table	2
Layout.....	3
Specifications.....	4
Packing List	5
Chapter 2 Hardware Installation	7
Before Installation	7
Hardware Features.....	8
Index to Connectors/Jumpers/Others.....	8
J1: RJ45 LAN /Adapter Connector with LED indicators	9
J2: External Speaker Header	10
J3: USB Connector	10
J4: Power Connector (4-pin 2.5mm JST).....	11
J5: Reset Header	11
J6 & JP1: External Battery Header and Battery Select Jumper	12
LDE1: Power/Watchdog & J7: External HDD LED Header	12
CN4: IDE hard Disk Connectors	13
CN5: 20-pin Floppy Connector.....	14
CN7: 26-pin Parallel Port Connector (26-pin 2.0mm IDC).....	15
CN6 & CN8: Serial Port Connectors RS-232C Pin Definitions	16
CN9: Keyboard/Mouse Connector	17
JP1: Clear CMOS Data.....	17
BUS1: PC/104 Bus Connectors.....	18
DIMM1: So-DIMM Socket.....	19
Chapter 3 Installing CRT and LCD Monitors	21
CRT Display (CN3).....	22
LCD FLAT PANEL DISPLAY.....	23
CN2: LCD Connector	24
CN1 provides control signals and power source for LCD inverter.	25
Chapter 4 BIOS Setup	27

Overview.....	27
BIOS Functions	28
BIOS Functions	28
Keyboard Convention	29
STANDARD CMOS SETUP.....	30
BIOS Features Setup.....	33
Chipset Features Setup.....	37
Power Management	40
PCI/Plug and Play	42
Peripheral Setup	44
Password Setup.....	47
Chapter 5 Driver and Utility.....	49
VGA Drivers	49
WIN98/WIN95 Driver	49
LAN Utility & Driver	49
Watchdog Timer.....	50
Watchdog Timer Setting.....	51
Watchdog Timer Enabled	52
Watchdog Timer Trigger	52
Watchdog Timer Disabled.....	53
Appendix.....	55
Dimension	55
Real-Time Clock and Non-Volatile RAM	56
CMOS RAM Map.....	58
I/O Port Address Map.....	59
Interrupt Request Lines (IRQ)	60
DMA Channel Map	61
DMA Controller 2.....	61
Serial Ports	62
Parallel Ports.....	66

Chapter 1 Introducing the FB2510 System Board

Overview

The FB2510 is an all-in-one, NS Geode low power PC/104 CPU board. This user's manual provides information on the physical features, installation, and BIOS setup of the FB2510.

Built to unleash the total potential of the Pentium Processor, the FB2510 is all-in-one CPU board computer capable of handling today's demanding requirements. Able to support 200-300 MHz CPUs, this system board supports 10/100M interface network port, 1 So-DIMM socket for up to 512MB PC-100 SDRAM, and a 4MB PCI-VGA controller that can support both LCD's and CRT's simultaneously or independently.

Each FB2510 has two ports for I/O communications. Two RS-232C ports are available.

The FB2510 is perfect for POS and POI applications, network systems, panel / MMI's, order entry kiosks, test equipment, OEM projects or as a motherboard for a panel PC. The unit is only 90 X 96 mm, offering unparalleled performance in a very small footprint.

Series Comparison Table

Model	FB2510
Processor	GX1-300Mhz
Chipset	CS5530A
1 So-DIMM Socket (Max. SDRAM)	512MB
VGA CRT/LCD	CS5530A
Watchdog Timer	Yes
Multi I/O Chip	2S1P
Enhanced IDE	Yes
USB	Yes
Ethernet (10/100Mbps)	One
Board Size	90mm x 96mm

Layout

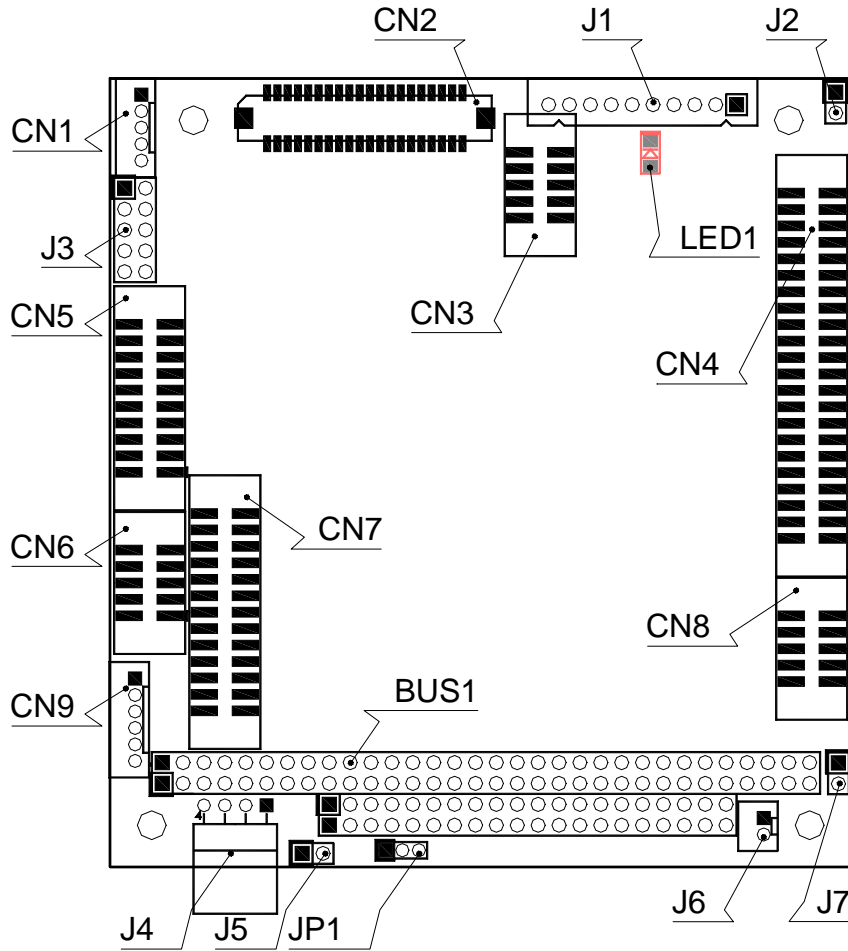

Specifications

- ❑ Supports 200~300 MHz NS Geode GX1 CPU.
- ❑ NS CS5530 (A) chipset with UMA architecture.
- ❑ 1 So-DIMM socket for up to 512MB PC-100 SDRAM
- ❑ One 100M/10M Ethernet port.
- ❑ Provides CRT, LCD interface with 1.5MB to 4MB shared memory.
- ❑ 1 parallel port, 2 RS-232, 1 floppy port and 1 PCI IDE interface.
- ❑ PS/2 compatible keyboard and mouse interface.
- ❑ Provides header for external speaker.
- ❑ Software programmable watchdog timer.
- ❑ 2 USB ports.
- ❑ Power requires +5V only, 1.2A maximum. (Base on 300MHz CPU and without LCD panel and LCD inverter)
- ❑ EMI Considered on every output signals.
- ❑ PC/104 form factor, 90.2 mm x 95.9 mm (3.55" x 3.775")

Packing List

Upon receiving the package, verify the following things. Should any of the mentioned happens, contact us for immediate service.

- Unpack and inspect the FB2510 package for possible damage that may occur during the delivery process.
- Verify the accessories in the package according to the packing list and see if there is anything missing or incorrect package is included.
- If the cable(s) you use to install the FB2510 is not supplied from us, please make sure the specification of the cable(s) is compatible with the FB2510 system board.

Note: after you install the FB2510 series, it is recommended that you keep the diskette or CD that contains drivers and document files, and keep the document copies, or unused cables in the carton for future use.

The following lists the accessories that may be included in your FB2510 package. Some accessories are optional items that are only shipped upon order.

- One FB2510 all-in-one PC/104 CPU board.
- One VGA (CRT interface) adapter cable.
- One 44-pin hard disk driver interface cable.
- One 20-pin to 34-pin floppy disk interface cable.
- Two serial port adapter cable and 1 parallel port interface cable. (10-pin IDC to DB-9)
- One PS/2 mouse port adapter cable
- One USB adapter cable with bracket. (Optional)
- One LAN adapter with FB4605A transfer board
- One compact disk includes software utility.

Chapter 2 Hardware Installation

To set up a FB2510 system board, complete the description in Chapter 2 and Chapter 3.

This chapter introduces the system board connectors & jumper settings, and guides you to apply them for field application.

Before Installation

Before you install the system board, make sure you follow the following descriptions.

1. Before removing the board from its anti-static bag, wear an anti-static strap to prevent the generation of Electricity Static Discharge (ESD). The ESD may be created from human body that touches the board. It may do damage to the board circuit.
2. Install or unplug any connector, module, or add-on card, be sure that the power is disconnected from the system board. If not, this may damage the system board components, module, or the add-on-card.
3. Installing a heat sink is necessary for heat dissipation from your CPU. If heat sink is not mounted, this may cause the CPU fail due to over-heating problem.

Hardware Features

Index to Connectors/Jumpers/Others

The following lists the connectors and jumpers to install the FB2510.

Item	Description
CN1	Control signals and power source for LCD inverter.
CN2	18-bit LCD interface connector
CN3	CRT connector
CN4	IDE hard disk connectors
CN5	Floppy connector
CN6 & CN8	RS232 connector for serial port 1 and 2
CN7	Parallel port connector
CN9	6-pin 2.0mm keyboard and mouse connector
J1	10-pin LAN port connector
J2	External Speaker Header
J3	USB connector header
J4	Power Connector
J5	Reset header
J6 & JP1	External Battery Header and Battery Select Jumper
J7	External HDD LED Header
BUS1	PC/104 Connector
LED1	Power/Watchdog LED
DIMM1	So-DIMM Socket

J1: RJ45 LAN /Adapter Connector with LED indicators

FB4605A is a RJ45 connector with 2 LEDs for LAN. The left side LED (orange) indicates data is being accessed and the right side LED (green) indicates on-line status. (On indicates on-line and off indicates off-line) J1 provide twist-pair signals of LAN port if you got LAN version and adapter board (FB4605A) with cable. The following table lists the pin assignments of J1 to RJ45 connector on the FB4605A LAN adapter board:

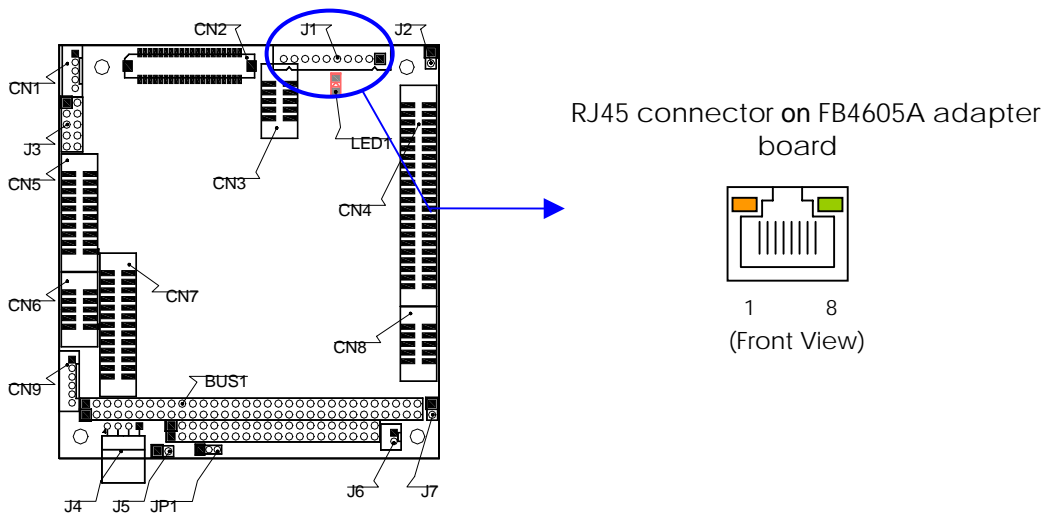

The following lists the pin assignment of J1.

J1	Signal	RJ45	J1	Signal	RJ45
1	TPTX+	1	6	Access LED	-
2	TPTX -	2	7	On-Line LED	-
3	TPRX+	3	8	Case GND	-
4	TPRX -	6	9	FBG1	4
5	LED Common	-	10	FBG1	5
			9	FBG2	7
			8	FBG2	8

J2: External Speaker Header

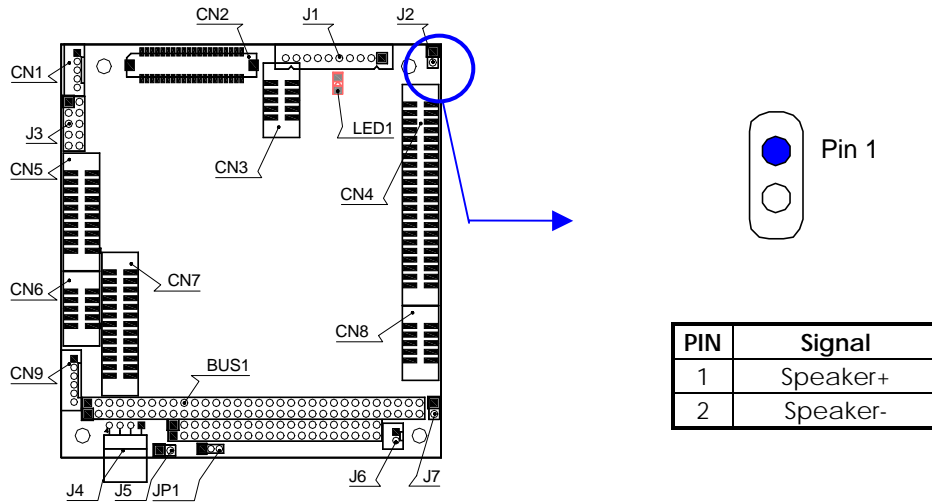

J3: USB Connector

J3 is a dual port USB connector. Any USB device can be attached to J3 with plug-and-play supported.

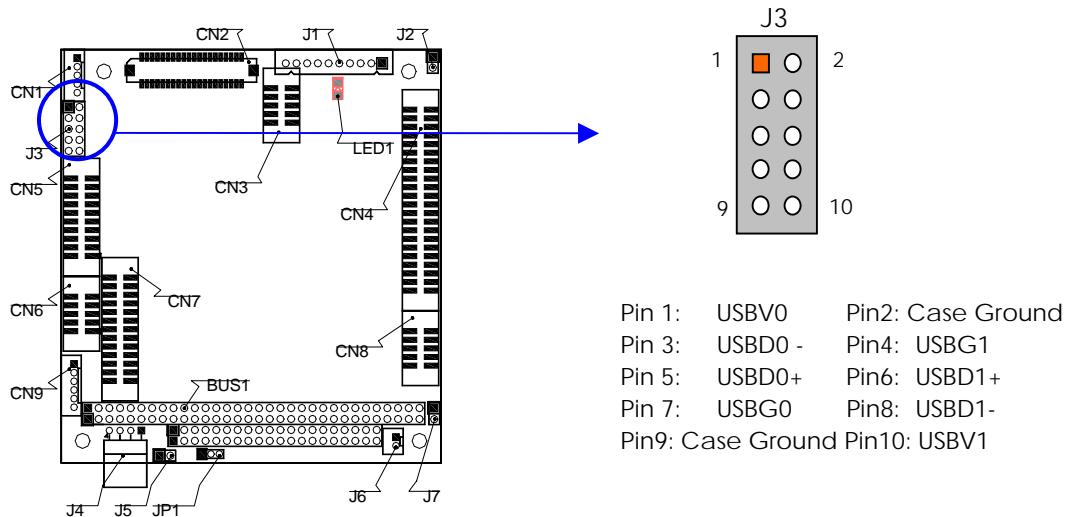

J4: Power Connector (4-pin 2.5mm JST)

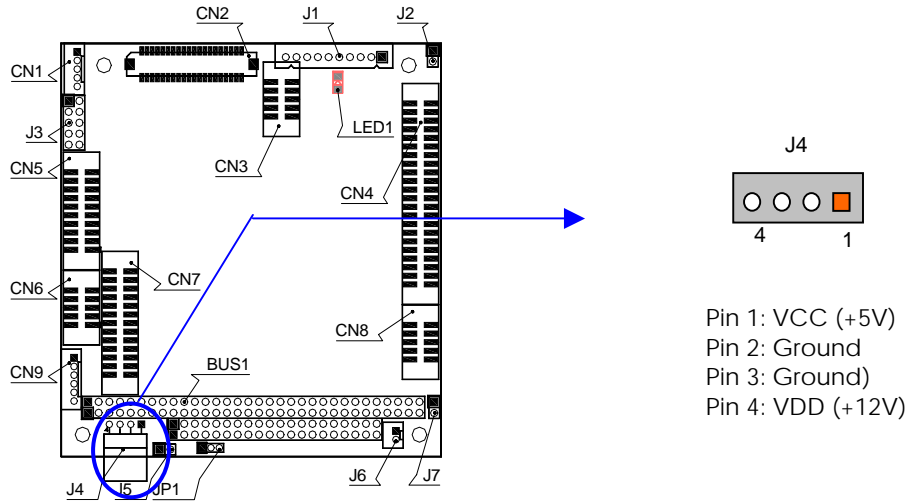

J5: Reset Header

J5 is a 2-pin header for connecting to system reset bottom. Short-circuit these 2 pins to hardware reset FB2510 as well as restart system. It is similar to power off the system and then power it on again.

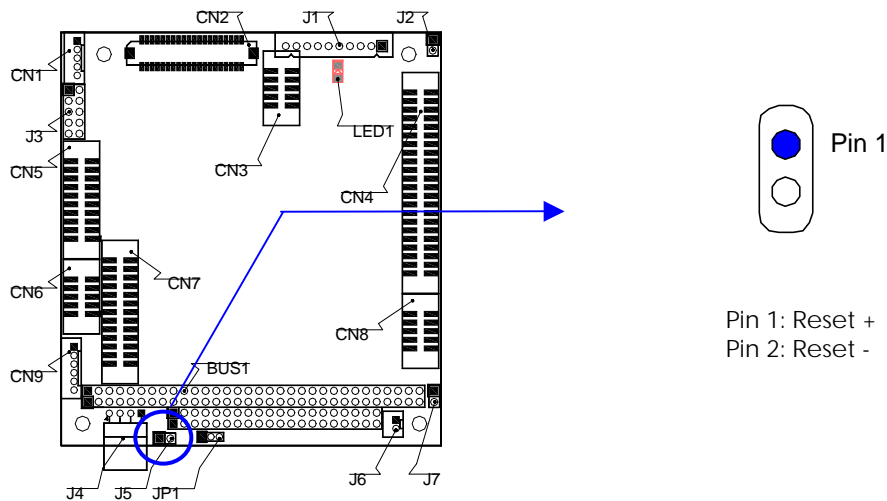

J6 & JP1: External Battery Header and Battery Select Jumper

J6 is used to connect an external battery pack if on-board Lithium battery is empty or not and please setting JP1 properly of on-board battery or external battery.

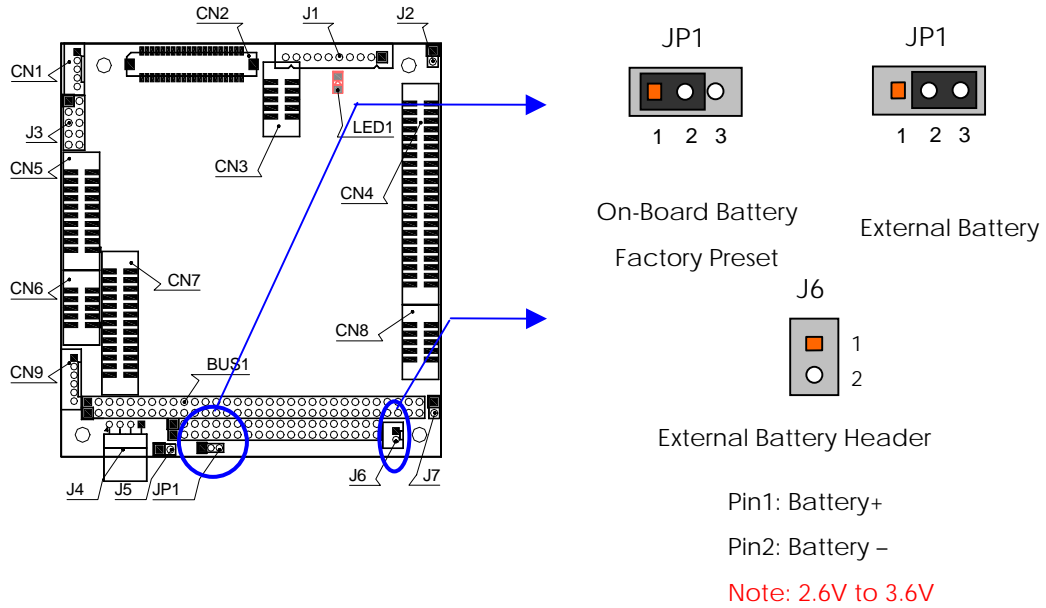

LDE1: Power/Watchdog & J7: External HDD LED Header

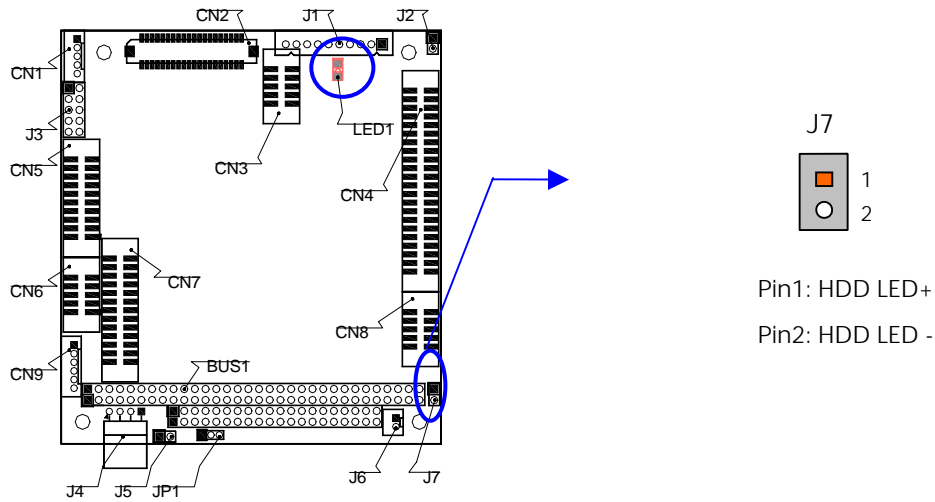

CN4: IDE hard Disk Connectors

CN4 is 44-pin 2.0mm IDC connectors. Use the included hard disk cables to attach up to two 2.5" hard disk drives.

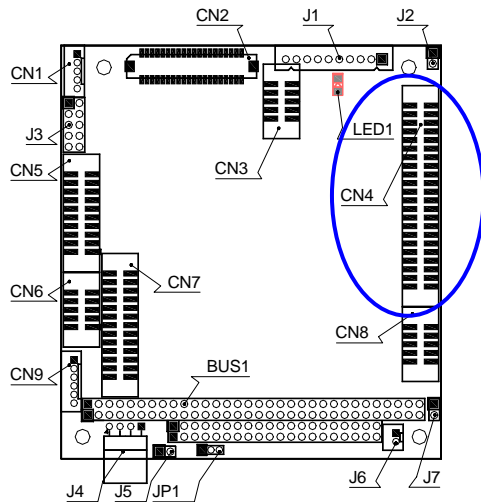

CN4 – Hard disk connector

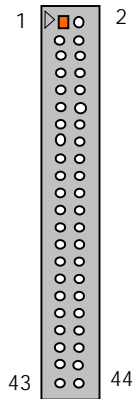

The following table lists the pin description of CN4.

Pin	Description	Pin	Description
1	-RESET	2	GROUND
3	DATA 7	4	DATA 8
5	DATA 6	6	DATA 9
7	DATA 5	8	DATA 10
9	DATA 4	10	DATA 11
11	DATA 3	12	DATA 12
13	DATA 2	14	DATA 13
15	DATA 1	16	DATA 14
17	DATA 0	18	DATA 15
19	GROUND	20	NOT USED
21	IDEDREQ	22	GROUND
23	-IOW A	24	GROUND
25	-IOR A	26	GROUND
27	IDEIORDYA	28	GROUND
29	-DACKA	30	GROUND
31	AINTE	32	GROUND
33	SA 1	34	Not Used
35	SA 0	36	SA 2
37	CS 0	38	CS 1
39	HD LED A	40	GROUND
41	VCC	42	VCC
43	GROUND	44	Not Used

CN5: 20-pin Floppy Connector

The included floppy drive interface cable is used to transfer 20-pin connector into standard 34-pin connector. The following table shows signal connections between 20-pin & 34-pin connectors.

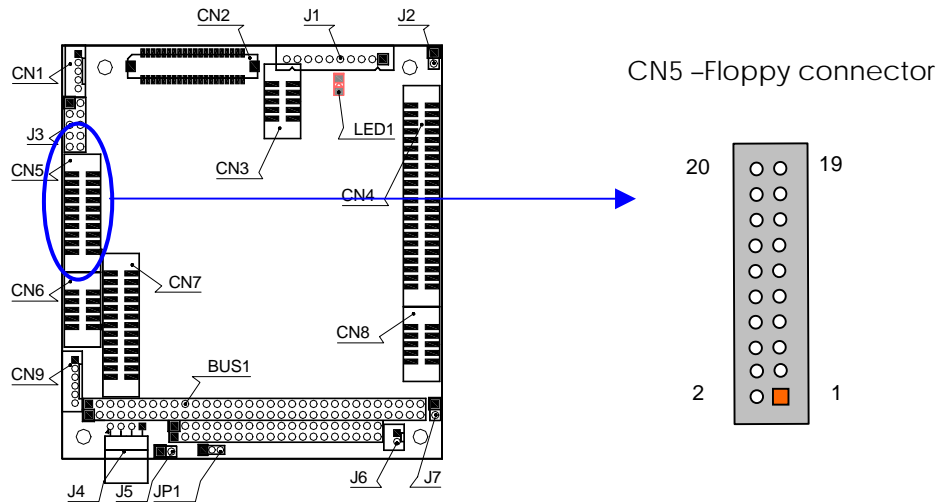

The following table shows signal connections.

20-pin	Signal	34-pin	20-pin	Signal	34-pin
1	Drive Enable A	2	12	Ground	23
2	-Index	8	13	-Write Enable	24
3	-Select A	12	14	-Track 0	26
4	Ground	11	15	-Write Protect	28
5	-Motor A	16	16	Ground	29
6	- Select B	14	17	-Read Data	30
7	-Motor B	10	18	-Head	32
8	Ground	9	19	-Disk Change	34
9	-Direction	18	20	Ground	31
10	-Step	20			
11	-Write Data	22	-	No Connection	Others

CN7: 26-pin Parallel Port Connector (26-pin 2.0mm IDC)

The included printer interface cable is used to transfer 26-pin connector into standard DB25 connector.

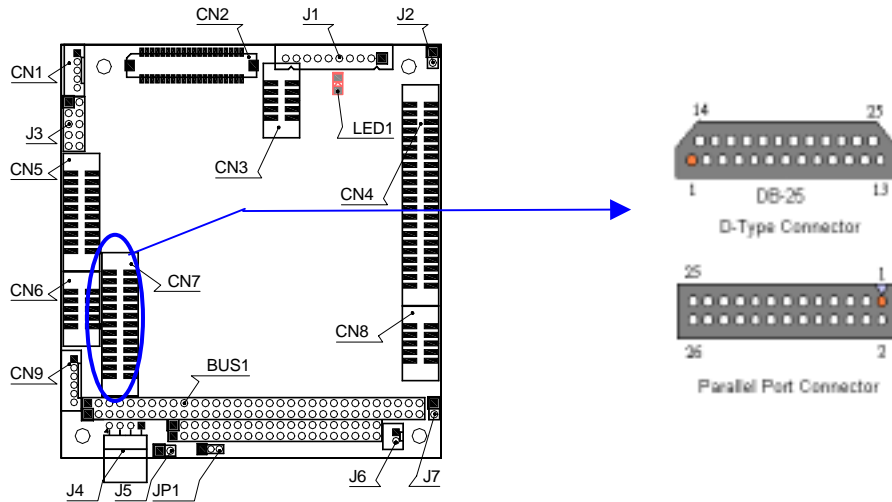

CN7	DB-25	Description	CN7	DB-25	Description
1	1	-STROBE	2	14	-AUTO FORM FEED
3	2	DATA 0	4	15	-ERROR
5	3	DATA 1	6	16	-INITIALIZE
7	4	DATA 2	8	17	-PRINTER SELECT IN
9	5	DATA 3	10	18	Ground
11	6	DATA 4	12	19	Ground
13	7	DATA 5	14	20	Ground
15	8	DATA 6	16	21	Ground
17	9	DATA 7	18	22	Ground
19	10	-ACKNOWLEDGE	20	23	Ground
21	11	BUSY	22	24	Ground
23	12	PAPER	24	25	Ground
25	13	PRINTER SELECT	26	--	No Used

CN6 & CN8: Serial Port Connectors RS-232C Pin Definitions

CN6 (COM1) & CN8 (COM2) are 10-pin 2.0mm IDC connectors. The included serial port adapter cables are used to transfer 10-pin 2.0mm IDC into standard DB-9 connector. The following tables show the signal connections of these connectors and the included adapter cable for CN6 & CN8:

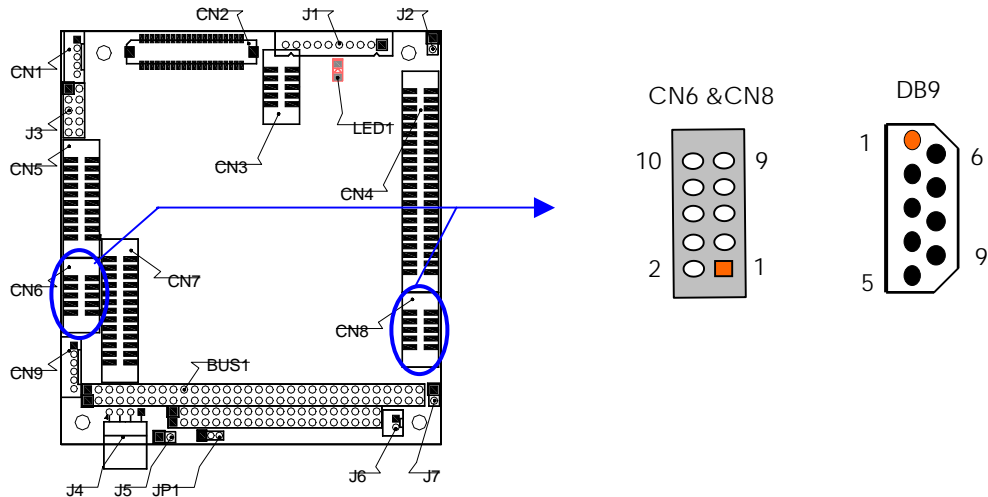

CN6 & CN8	RS-232 Signal	DB9
1	-DCD2	1
2	-DSR2	6
3	RXD2	2
4	-RTS2	7
5	-TXD2	3
6	-CTS2	8
7	-DTR2	4
8	-RI2	9
9	GROUND	5
10	GROUND	Shield

CN9: Keyboard/Mouse Connector

CN9 is a 6-pin 2.0mm JST connector, use the included adapter cable you can attach standard PS/2 type keyboard and mouse.

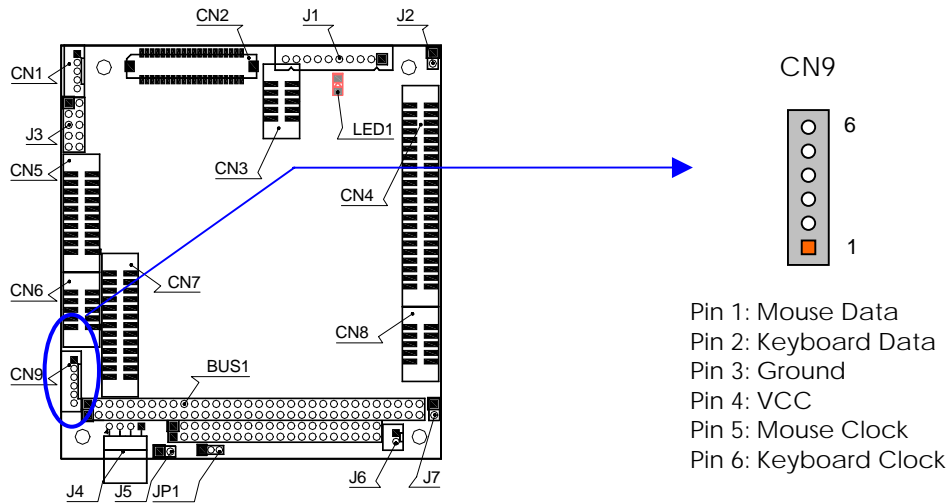

JP1: Clear CMOS Data

You can use JP1 to clear CMOS data. The CMOS store information like system date, time, boot up device, password, IRQ... that are set up with the BIOS. To clear the CMOS, set JP1 to open then return to 1-2 before system is power-off. The default setting is 1-2.

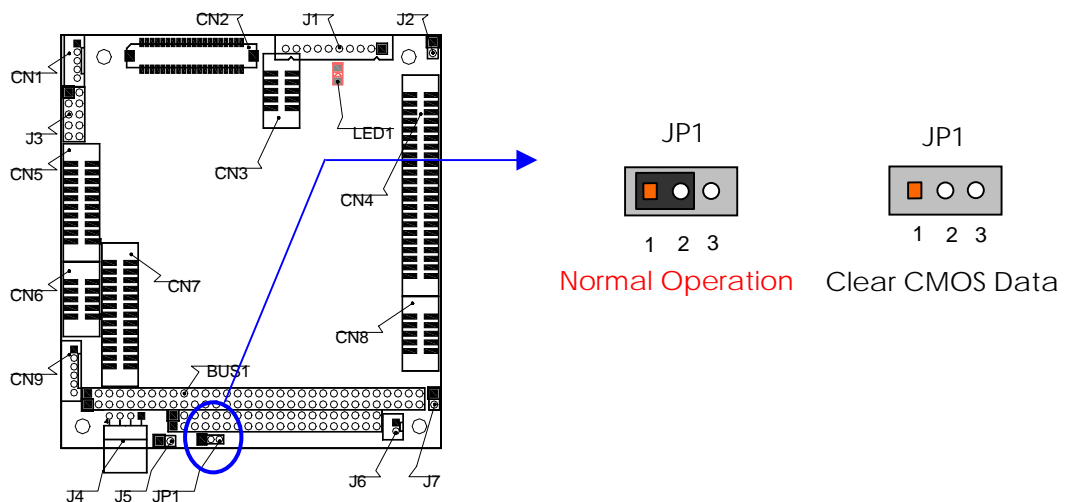

BUS1: PC/104 Bus Connectors

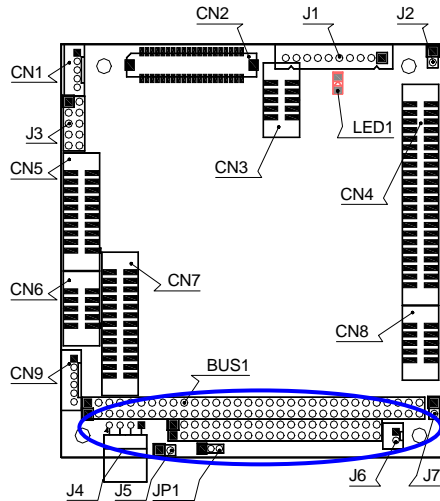

BUS1 – BUS A & B

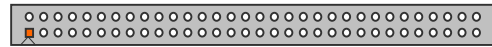

BUS1 – BUS C & D

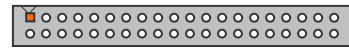

PC/104 A&B Pin

Pin	Signal	Pin	Signal	Pin	Signal	Pin	Signal
A1	-	A17	SA14	B1	Ground	B17	-DACK1
A2	SD7	A18	SA13	B2	RSTDRV	B18	DRQ1
A3	SD6	A19	SA12	B3	+5V	B19	-
A4	SD5	A20	SA11	B4	IRQ9	B20	BUSCLK
A5	SD4	A21	SA10	B5	-5V	B21	IRQ7
A6	SD3	A22	SA9	B6	DRQ2	B22	IRQ6
A7	SD2	A23	SA8	B7	-12V)	B23	IRQ5
A8	SD1	A24	SA7	B8	-ZWS	B24	IRQ4
A9	SD0	A25	SA6	B9	+12V	B25	IRQ3
A10	IORDY	A26	SA5	B10	Key1	B26	-DACK2
A11	AEN	A27	SA4	B11	-MEMW	B27	TC
A12	SA19	A28	SA3	B12	-MEMR	B28	ALE
A13	SA18	A29	SA2	B13	-IOW	B29	+5V
A14	SA17	A30	SA1	B14	-IOR	B30	OSC
A15	SA16	A31	SA0	B15	-DACK3	B31	Ground
A16	SA15	A32	Ground	B16	DRQ3	B32	Ground

PC/104 C & D Pin

Pin	Signal	Pin	Signal	Pin	Signal	Pin	Signal
C1	GND	C11	MEMW#	D1	Ground	D11	-DACK#5
C2	SBHE	C12	SD8	D2	MEMCS16#	D12	DREQ5
C3	LA23	C13	SD9	D3	IOCS16#	D13	DACK#6
C4	LA22	C24	SD10	D4	IRQ10	D14	DREQ6
C5	LA21	C25	SD11	D5	IRQ11	D15	DACK#7
C6	LA20	C26	SD12	D6	IRQ12	D16	DREQ7
C7	LA19	C27	SD13	D7	IRQ15	D17	VCC
C8	LA18	C28	SD14	D8	IRQ14	D18	-
C9	LA17	C29	SD15	D9	DACK#0	D19	GND
C10	MEMR#	C20	KEY	D10	DREQ0	D20	GND

DIMM1: So-DIMM Socket

The DIMM1 socket on the solder side accepts 32MB to 512MB PC-100 SDRAM modules.

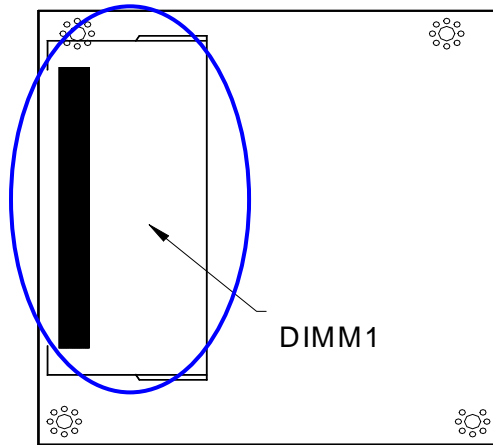

Chapter 3 Installing CRT and LCD Monitors

This chapter describes the configuration and installation procedure of LCD and CRT displays. Both CRT and LCD displays may be used at the same time. Only TFT type LCDs may be used. CRT monitors should work with no problem under Windows 95/98. However, each type of LCD requires different BIOS.

The FB2510 supports a CRT colored monitor and a TFT LCD (DSTN LCDs are not supported with this board). It can be connected to create a compact video solution for the industrial environment. 4MB of RAM on-boarded allows a maximum CRT resolution of 1024X768 with 256 colors and a LCD resolution of 800X600 with 64k colors. Different VGA display modes are possible, but your monitor must possess certain characteristics (different modes require different drivers to display the mode desired).

- LCD Flat Panel Display
- CRT & LCD Display

CRT Display (CN3)

The following table and figure illustrate the pin definition of CN3 and D-sub 15-pin on the CRT adapter cable:

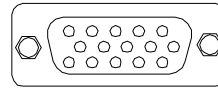
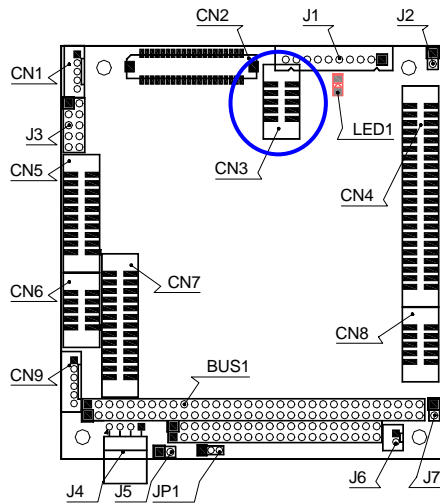

- Pin 1: Red
- Pin 2: Green
- Pin 3: Blue
- Pin 13: Hsync
- Pin 14: Vsync
- Pin 12: DDC Data
- Pin 15: DDC Clock
- Pin 5 & 10: Digital Ground
- Pin 6,7,8: Analog Ground
- Others: Not Used

CN3	Signal	DB-15	CN3	Signal	DB15
1	RED	1	2	Case Ground	Case
3	GREEN	2	4	Digital Ground	5,10
5	BLUE	3	6	Analog Ground	6,7,8
7	VSYNC	14	8	DDC Data	12
9	HSYNC	13	10	DDC Clock	15

LCD FLAT PANEL DISPLAY

Each LCD model requires specific BIOS in order to work properly. If you want to use a panel that your board was not originally designed for then, please send an email to support@fabiatech.com and state the LCD type and full specification you use.

The following shows the block diagram of using FB2510 for LCD display.

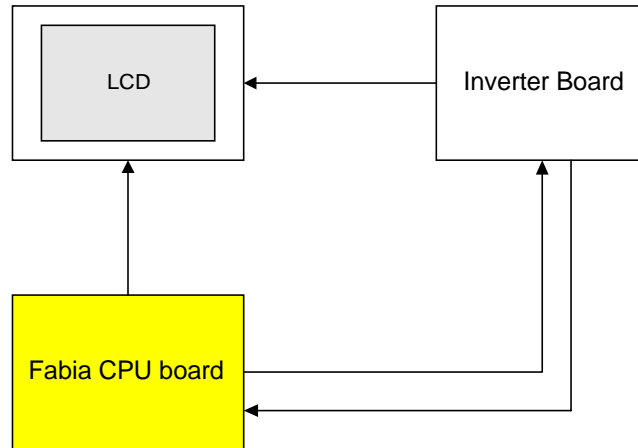

LCD Panel Block Diagram

The block diagram shows that FB2510 still needs components to be used with a LCD panel. It needs control for the brightness and the contrast of the LCD panel while inverter board is the one that supplies the high voltage to drive the LCD panel.

NOTE: Be careful with the pin orientation when installing connectors and the cables. A wrong connection can easily destroy your LCD panel. The pin 1 of the cable connectors is indicated with a sticker and the pin1 of the ribbon cable usually has a different color.

CN2: LCD Connector

CN2 is an 18-bit LCD interface connector. The pin assignments are listed in the following table.

CN2	Description	CN2	Description	CN2	Description	CN2	Description
1	+5V	21	FPD8	2	+5V	22	FPD9
3	Ground	23	FPD10	4	Ground	24	FPD11
5	+ 3.3V	25	N.C	6	+ 3.3V	26	N.C
7	R/L	27	FPD12	8	Ground	28	FPD13
9	N.C	29	FPD14	10	N.C	30	FPD15
11	FPD0	31	FPD16	12	FPD1	32	FPD17
13	FPD2	33	Ground	14	FPD3	34	Ground
15	FPD4	35	FPCLK	16	FPD5	36	FPVSYNC
17	N.C	37	FPDISP	18	N.C	38	FPHSYNC
19	FPD6	39	U/D	20	FPD7	40	FPVDDEN

Note: N.C. means not connected, it is reserved for upgraded signals.

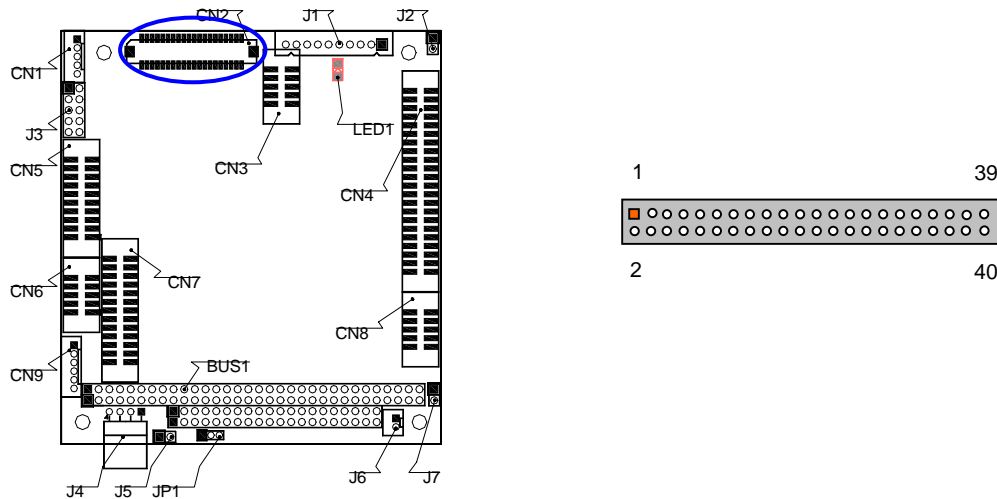

CN1 provides control signals and power source for LCD inverter.

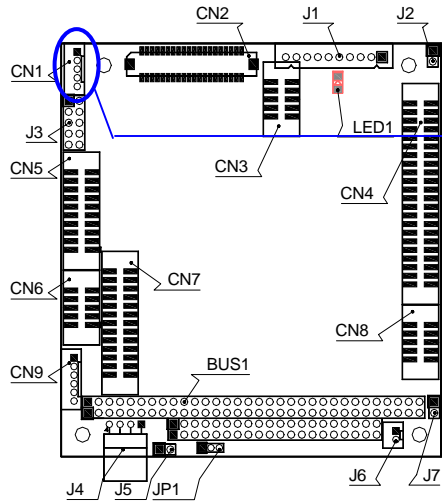

CN1

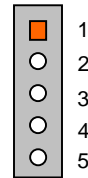

- Pin1: +12V
- Pin2: Ground
- Pin3: FPBLKEN
- Pin4 VR.
- Pin5: +5V

Note: +12V is come from J4 only

Chapter 4 BIOS Setup

This chapter describes the BIOS setup.

Overview

BIOS are a program located on a Flash memory chip on a circuit board. It is used to initialize and set up the I/O peripherals and interface cards of the system, which includes time, date, hard disk drive, the ISA bus and connected devices such as the video display, diskette drive, and the keyboard. This program will not be lost when you turn off the system.

The BIOS provides a menu-driven interface to the console subsystem. The console subsystem contains special software, called firmware that interacts directly with the hardware components and facilitates interaction between the system hardware and the operating system.

The BIOS default values ensure that the system will function at its normal capability. In the worst situation the user may have corrupted the original settings set by the manufacturer.

All the changes you make will be saved in the system RAM and will not be lost after power-off.

When you start the system, the BIOS will perform a self-diagnostics test called Power On Self Test (POST) for all the attached devices, accessories, and the system. Press the [Del] key to enter the BIOS Setup program, and then the main menu will show on the screen.

Note: Change the parameters when you fully understand their functions and subsequence.

ROM PCI/ISA BIOS (2A434FJD)
CMOS SETUP UTILITY
AWARD SOFTWARE, INC.

STANDARD CMOS SETUP	INTEGRATED PERIPHERALS
BIOS FEATURES SETUP	SUPERVISOR PASSWORD
CHIPSET FEATURES SETUP	USER PASSWORD
POWER MANAGEMENT SETUP	IDE HDD AUTO DETECTION
PNP/PCI CONFIGURATION	SAVE & EXIT SETUP
LOAD BIOS DEFAULTS	EXIT WITHOUT SAVING
LOAD SETUP DEFAULTS	
Esc : Quit	↑ ↓ → ← : Select Item
F10 : Save & Exit Setup	(Shift)F2 : Change Color

BIOS Functions

BIOS Functions

On the menu, you can perform the following functions

1. Standard CMOS Setup-
2. BIOS Features Setup
3. Chipset Features Setup
4. Advanced Chipset Setup
5. Power Management Setup
6. PNP/PCI Configuration
7. Load BIOS Defaults
8. Load Setup Default
9. Integrated Peripherals Setup
10. User Password
11. IDE Auto Detect
12. Save & Exit Setup
13. Exit Without Saving

Keyboard Convention

On the BIOS, the following keys can be used to operate and manage the menu:

Item	Function
ESC	To exit the current menu or message
Page Up/Page Down	To select a parameter
F1	To display the help menu if you do not know the purpose or function of the item you are going to configure
F2/F3	To change the color of the menu display. F2 is to go forward and F3 to go backward
UP/Down Arrow Keys	To go upward or downward to the desired item

STANDARD CMOS SETUP

This section describes basic system hardware configuration, system clock setup and error handling. If the CPU board is already installed in a working system, you will not need to select this option anymore.

```

ROM PCI/ISA BIOS (2A434FJA)
STANDARD CMOS SETUP
AWARD SOFTWARE, INC.

Date (mm:dd:yy) : Fri, Jan 4 2002
Time (hh:mm:ss) : 16 : 4 : 52

HARD DISKS          TYPE    SIZE  CYLS  HEAD  PRECOMP  LANDZ  SECTOR  MODE
-----
Primary Master    :    0    0    0    0    0    0    0    AUTO
Primary Slave     :    0    0    0    0    0    0    0    AUTO

Drive A : 1.44M, 3.5 in.
Drive B : None

Video  : EGA/UGA
Halt On : No Errors

ESC : Quit          ↑ ↓ + + : Select Item      PU/PD/+/- : Modify
F1  : Help          (Shift)F2 : Change Color
    
```

□ **Date & Time Setup**

Highlight the <Date> field and then press the [Page Up] /[Page Down] or [+]/[-] keys to set the current date. Follow the month, day and year format.

Highlight the <Time> field and then press the [Page Up] /[Page Down] or [+]/[-] keys to set the current date. Follow the hour, minute and second format.

The user can bypass the date and time prompts by creating an AUTOEXEC.BAT file. For information on how to create this file, please refer to the MS-DOS manual.

□ **Floppy Setup**

The <Standard CMOS Setup> option records the types of floppy disk drives installed in the system.

To enter the configuration value for a particular drive, highlight its corresponding field and then select the drive type using the left-or right-arrow key.

□ **Hard Disk Setup**

The BIOS supports various types for user settings, The BIOS supports <Pri Master>, <Pri Slave>, so the user can install up to four hard disks. For the master and slave

jumper, please refer to the hard disk's installation descriptions and the hard disk jumper settings.

You can select <AUTO> under the <TYPE> and <MODE> fields. This will enable auto detection of your IDE drives during boot up. This will allow you to change your hard drives (with the power off) and then power on without having to reconfigure your hard drive type. If you use older hard disk drives, which do not support this feature, then you must configure the hard disk drive in the standard method as described above by the <USER> option.

□ **Video**

This option selects the type of adapter used for the primary system monitor that must match your video display card and monitor. Although secondary monitors are supported, you do not have to select the type in Setup.

You have two ways to boot up the system:

When VGA set as primary and monochrome set as secondary, the selection of the video type is "VGA Mode".

When monochrome set as primary and VGA set as secondary, the selection of the video type is "Monochrome Mode".

□ **Error Halt**

This option determines whether the computer will stop if an error is detected during power up.

No errors	The system boot will not be stopped for any error that may be detected.
All errors	Whenever the BIOS detect a non-fatal error the system will be stopped and you will be prompted.
All, But Keyboard	The system boot will not stop for a keyboard error; it will stop for all other errors.
All, But Diskette	The system boot will not stop for a disk error; it will stop for all other errors.
All, But Disk/Key	The system boot will not stop for a keyboard or disk error; it will stop for all other errors.

□ **Memory**

This option is display-only which is determined by POST (Power On Self Test) of the BIOS.

□ **Base Memory**

The POST of the BIOS will determine the amount of base (or conventional) memory

installed in the system. The value of the base memory is typically 512K for systems with 512K memories installed on the motherboard, or 640K for systems with 640K or more memory installed on the motherboard.

□ **Extended Memory**

The BIOS determines how much extended memory is present during the POST. This is the amount of memory located above 1MB in the CPU's memory address map.

□ **Other Memory**

This refers to the memory located in the 640K to 1024K-address space. This is memory that can be used for different applications. DOS uses this area to load device drivers to keep as much base memory free for application programs. Most use for this area is Shadow RAM.

□ **Total Memory**

System total memory is the sum of basic memory, extended memory, and other memory.

BIOS Features Setup

This section describes the configuration entries that allow you to improve your system performance, or let you set up some system features according to your preference. Some entries here are required by the CPU board's design to remain in their default settings.

ROM PCI/ISA BIOS (2A434FJA)			
BIOS FEATURES SETUP			
AWARD SOFTWARE, INC.			
Virus Warning	: Disabled	Video BIOS Shadow	: Enabled
CPU Internal Cache	: Enabled	C8000-CBFFF Shadow	: Disabled
Quick Power On Self Test	: Enabled	CC000-CFFFF Shadow	: Disabled
Boot Sequence	: C,A,SCSI	D0000-D3FFF Shadow	: Disabled
Boot Up Floppy Seek	: Enabled	D4000-D7FFF Shadow	: Disabled
Boot Up NumLock Status	: On	D8000-DBFFF Shadow	: Disabled
Boot Up System Speed	: High	DC000-DFFFF Shadow	: Disabled
Gate A20 Option	: Normal	Cyrix 6x86/MII CPUID	: Enabled
Memory Parity Check	: Enabled		
Typematic Rate Setting	: Disabled		
Typematic Rate (Chars/Sec)	: 6		
Typematic Delay (Msec)	: 250		
Security Option	: Setup		
PCI/UGA Palette Snoop	: Disabled	ESC : Quit	↑↓++ : Select Item
OS Select For DRAM > 64MB	: Non-OS2	F1 : Help	PU/PD/+/- : Modify
Report No FDD For WIN 95	: No	F5 : Old Values (Shift)	F2 : Color
		F6 : Load BIOS Defaults	
		F7 : Load Setup Defaults	

Virus Warning

This option may flash on the screen. During and after the system boots up, any attempt to write to the boot sector or partition table of the hard disk drive will halt the system and the following error message will appear, in the mean time, you can run an anti-virus program to locate the problem.

Available Options: Disabled, Enabled

Default setting: Disable

CPU Internal Cache

This functions speeds up memory access. The FB2510 GXM Cyrix CPU has an internal cache.

Available options: Disabled, Enabled

Default setting: Enabled

Quick Power On Self Test

This option speeds up Power On Self Test (POST) after you power on the computer. If it is set to Enable, BIOS will shorten or skip some items' checks during POST.

Available options: Disabled, Enabled

Default setting: Enable

Boot Sequence

This field specifies which device the system looks first upon power on.

Default setting: C, CDROM, A

Boot Up Floppy Seek

During POST, BIOS will determine if the floppy disk drive installed is 40 or 80 tracks. 360K types are 40 tracks while 720K, 1.2M and 1.44M are all 80 tracks.

Enabled	BIOS searches for floppy disk drive to determine if it is 40 or 80 tracks. Note that BIOS cannot tell from 720K, 1.2M or 1.44M drive type, as they are all 80 tracks.
Disabled	BIOS will not search for the type of floppy disk drive by track number. Note that there will not be any warning message if the drive installed is 360K.

Boot Up Numlock status

This field is used to activate the Num Lock function upon system boot. If the setting is on, after a boot, the Num Lock light is lit, and user can use the number key.

Available options: On, Off

Default setting: On

Gate A20 Option

This item is chosen as <Normal>, the A20 signal is controlled by keyboard controller or chipset hardware. The selection is "Fast" Port 92 or a chipset specific method controls means the A20 signal

Available options: Normal, Fast

Default setting: Normal

□ **Typematic rate Setting**

This function specifies the keystroke repeat rate when a key is pressed and held down.

Available options: Disable, Enable

Default setting: Disable

□ **Typematic Rate (Chars/Sec)**

Typematic Rate sets the rate at which characters on the screen repeat when a key is pressed and held down.

Available options: 6, 8, 10, 12, 15, 20, 24, or 30 characters per second

Default setting: 6

□ **Typematic Delay (Msec)**

The number selected indicates the time period between two identical characters appearing on screen.

Available options: 250, 500, 750 and 1000

Default setting: 250

□ **Security Option**

This field enables password checking every time the computer is powered on or every time the BIOS Setup is executed. If ***Always*** is chosen, a user password prompt appears every time and the BIOS Setup Program executes and the computer is turned on. If ***Setup*** is chosen, the password prompt appears if the BIOS executed.

Available options: Setup, Always

Default setting: Setup

□ **PCI/VGA Palette Snoop**

This option must be set to Enabled if any ISA adapter card installed in the computer requires VGA palette snooping.

Available options: Enable, Disable

Default setting: Disable

□ **OS Select for DRAM > 64MB**

This segment is specifically created for OS/2 when DRAM is large than 64MB,if you operating system is OS/2 and DRAM used is large 64MB, You have to select "OS/2" OTHERWISE (under non -OS/2), default is NON OS/2.

Available options: Non-OS/2, OS/2

Default setting: Non-OS/2

□ **Report No FDD for Win95**

This option allows Windows 95 to share IRQ6 (assigned to a floppy disk drive) with other peripherals in case the driver does not exist.

Available options: Enable, Disable

Default setting: Disable

□ **Video, 16k Shadow C000 - DC00, 16k shadow**

These fields control the location of the contents of the 16KB of ROM beginning at the specified memory location. If no adapter ROM is using the named ROM area, this area is made available to the local bus. The settings are:

1. **Disabled:** The video ROM is not copied to RAM. The contents of the video ROM cannot be read from or written to cache memory.
2. **Enabled:** The contents of C000h - CFFFh are written to the same address in system memory (RAM) for faster execution.

Available options: Disabled, Enabled,

Default setting: Disable (Video shadow is Enable)

Chipset Features Setup

This section describes the configuration of the board's chipset features.

**ROM PCI/ISA BIOS (2A434FJA)
CHIPSET FEATURES SETUP
AWARD SOFTWARE, INC.**

<pre> SDRAM CAS latency Time : 2 T SDRAM Clock Ratio Div By : 3 16-bit I/O Recovery (CLK): 5 8-bit I/O Recovery (CLK): 5 USB Controller : Enabled USB Legacy Support : Disabled Multiple Monitor Support : PCI First Video Memory Size : 1.5 M Display status : CRT Flat Panel Resolution : 640x480 </pre>	<pre> ESC : Quit ↑↓↓+ : Select Item F1 : Help PU/PD/+/ - : Modify F5 : Old Values (Shift)F2 : Color F6 : Load BIOS Defaults F7 : Load Setup Defaults </pre>
--	---

- **SDRAM CAS AUTO Latency Time**

This field specifies the latency for the Synchronous DRAM system memory signals.

Available Options: 3T, 2T

Default setting: 2 T

- **SDRAM Clock Ration Div by**

When 100 MHz external frequency runs the system, the system will run at 3 cycle clocks. When 66 MHz runs the system, the system will run at 4 cycle clocks. Selecting Auto, the system will be auto adaptive depending on the SDRAM clock that is installed.

Available Options: 4T, 3T

Default setting: 3 T

8bit I/O Recovery Time

The recovery time is the length of time, measured in CPU clocks, which the system will delay after achieving an input/output request. This delay takes place to wait for the I/O to complete the request. This field specifies the recovery time for 8bit I/O.

Available Options: Disabled, 1 –8 Sysclk

Default setting: 5 Sysclk

16Bit I/O Recovery Time

This field specifies the recovery time for 16Bit I/O.

Available Options: Disabled, 1 –8 Sysclk

Default setting: 5 Sysclk

USB Controller

Select Enabled if a USB device is installed to the system. If Disabled are selected, the system will not be able to use a USB device.

Available Options: Disabled, Enabled

Default setting: Enabled

USB Legacy Support

Select Enabled if you system contains a USB controller and you have USB keyboard and mouse. If Disabled are selected, the system will not be able to use a USB device under DOS.

Available Options: Disabled, Enabled

Default setting: Disable

Video Memory

This field specifies which VGA display memory. You can select either Video memory on the VGA. The setting share onboard memory.

Available Options: 1.5MB, 2.5MB, and 4MB

Default setting: 1.5MB

□ **Display state**

This field specifies which VGA display will be used when the system is boot. You can select either the LCD or the CRT booting on the VGA.

Available Options: Both, LCD, and CRT

Default setting: CRT

□ **Flat Panel Resolution**

When use the LCD the field specifies which select display resolution for different TFT LCD display type.

Available Options: 640x480, 800x600 and 1024x768

Default setting: 640X480

Power Management

ROM PCI/ISA BIOS (2A434FJ9) POWER MANAGEMENT SETUP AWARD SOFTWARE, INC.			
Power Management	: Disabled	IRQ1 (KeyBoard)	: ON
** PM Timers **		IRQ3 (COM 2)	: OFF
Doze Mode	: Disabled	IRQ4 (COM 1)	: OFF
Standby Mode	: Disabled	IRQ5 (LPT 2)	: OFF
HDD Power Down	: Disabled	IRQ6 (Floppy Disk)	: OFF
MODEM Use IRQ	: NA	IRQ7 (LPT 1)	: OFF
Throttle Duty Cycle	: 33.3 %	IRQ9 (IRQ2 Redir)	: OFF
		IRQ10 (Reserved)	: OFF
		IRQ11 (Reserved)	: OFF
		IRQ12 (PS/2 Mouse)	: OFF
		IRQ13 (Coprocessor)	: OFF
		IRQ14 (Hard Disk)	: OFF
		IRQ15 (Reserved)	: OFF
		ESC : Quit	↑↓←→ : Select Item
		F1 : Help	PU/PD/+/- : Modify
		F5 : Old Values	(Shift)F2 : Color
		F6 : Load BIOS Defaults	
		F7 : Load Setup Defaults	

Power Management

The field determines how much power consumption is needed for the system after selecting the below items.

Doze Mode

This field defines the continuous idle time before the system enters Doze Mode.

Standby Mode

This field defines the continuous idle time before the system enters Standby Mode. If any item defined is enabled & active Standby timer will be reloaded.

HDD Power Down

This field specifies the power conserving state that the hard disk drive enters after the specified period of hard drive inactivity has expired.

Available Options: Disabled, Standby, Suspend

Default setting: Disabled

Modem Use IRQ

This field specifies the IRQ of the modem.

□ **IRQ**

These options enable event monitoring. When the computer is in a power saving mode, activity on the named interrupt request line is monitored by BIOS. When any activity occurs, the computer enters Full On mode.

PCI/Plug and Play

ROM PCI/ISA BIOS (2A434F19)
 PNP/PCI CONFIGURATION
 AWARD SOFTWARE, INC.

PNP OS Installed : No Resources Controlled By : Manual Reset Configuration Data : Disabled IRQ-3 assigned to : Legacy ISA IRQ-4 assigned to : Legacy ISA IRQ-5 assigned to : PCI/ISA PnP IRQ-7 assigned to : PCI/ISA PnP IRQ-9 assigned to : PCI/ISA PnP IRQ-10 assigned to : Legacy ISA IRQ-11 assigned to : Legacy ISA IRQ-12 assigned to : PCI/ISA PnP IRQ-14 assigned to : PCI/ISA PnP IRQ-15 assigned to : PCI/ISA PnP DMA-0 assigned to : PCI/ISA PnP DMA-1 assigned to : PCI/ISA PnP DMA-3 assigned to : PCI/ISA PnP DMA-5 assigned to : PCI/ISA PnP DMA-6 assigned to : PCI/ISA PnP DMA-7 assigned to : PCI/ISA PnP	PCI IRQ Activated By : Level Used MEM base addr : N/A ESC : Quit ↑↓←→ : Select Item F1 : Help PU/PD/+/- : Modify F5 : Old Values (Shift)F2 : Color F6 : Load BIOS Defaults F7 : Load Setup Defaults
---	--

- PNP O/S Installed**

Set to Yes to inform BIOS that the operating system can handle Plug and Play (PnP) devices.

Available Options: Yes, No

Default setting: No

- Resources Controlled By:** Auto, Manual

If you select Auto, all the interrupt request (IRQ), DMA assignment, and Used DMA fields disappear, as the BIOS automatically assigns them. The default value is "Manual".

Available Options: Auto, Manual

Default setting: Manual

- Reset Configuration Data:** Enable, Disable

If you select Enable to reset Extended System Configuration Data (ESCD) when you exit setup if you have installed a new add-on and the system reconfiguration has caused such a serious conflict that the operation operating system cannot boot.

Available Options: Enable, Disable

Default setting: Disable

□ **IRQ-n/DMA-n Assigned:** PCI/ISA PnP, Legacy ISA

The resources are controlled manually.

1. Legacy ISA Devices compliant with the original PC AT bus specification, requiring a specific interrupt/DMA (such as IRQ4, IRQ3 for serial port 1 and 2).
2. PCI/ISA PnP Devices compliant with Plug and play standard, whether designed for PCI or ISA bus.

□ **Use MEM base addr. : Resources Controlled By:** Auto, Manual

Select a base address for the memory area used by any peripheral that requires high memory.

Available Options: N/A, C800, CC00, D000, D400, D800 and DC00

Default setting: N/A

Peripheral Setup

This section describes the function of peripheral features.

**ROM PCI/ISA BIOS (2A434FJA)
INTEGRATED PERIPHERALS
AWARD SOFTWARE, INC.**

IDE HDD Block Mode	: Enabled	Build in CPU Audio	: Enabled
Primary IDE Channel	: Enabled	Audio I/O Base Address	: 220H
Master Drive PIO Mode	: Auto	MPU-401 I/O Base Address	: 330H
Slave Drive PIO Mode	: Auto	Audio IRQ Select	: IRQ 5
IDE Primary Master UDMA	: Auto	Audio Low DMA Select	: DMA 1
IDE Primary Slave UDMA	: Auto	Audio High DMA Select	: DMA 5
Onboard FDC Controller	: Enabled		
Onboard Serial Port 1	: 3F8/IRQ4		
Onboard Serial Port 2	:		
UART Mode Select	:		
Onboard Parallel Port	:		
Parallel Port Mode	:		
ECP Mode Use DMA	: 3		

IDE HDD Block Mode

This option allows your hard disk controller to use the fast block mode to transfer data to and from your hard disk drive (HDD).

IDE PIO

IDE hard drive controllers can support up to two separate hard drives. These drives have a master/slave relationship, which is determined by the cabling configuration used to attach them to the controller. Your system supports one IDE controller – a primary and a secondary – so you have the ability to install up to four separate hard disks.

PIO means Programmed Input/Output. Rather than have the BIOS issue a series of commands to affect a transfer to or from the disk drive, PIO allows the BIOS to tell the controller what it wants and then let the controller and the CPU perform the complete task by them. This is simpler and more efficient (and faster). Your system supports five modes, numbered from 0 to 4, which primarily differ in timing. When Auto is selected, the BIOS will select the best available mode.

OnBoard FDC

This field enables the floppy drive controller on the FB2510.

Available Options: Auto, Disabled, Enabled

Default setting: Auto

OnBoard Serial Port 1

These fields select the I/O port address for each Serial port.

Available Options: Disabled, 3F8H/IRQ4, 2F8H/IRQ3, 3E8H/IRQ4, 2E8H/IRQ3

Default setting: 3F8H/IRQ4

OnBoard Serial Port 2

These fields select the I/O port address for each Serial port.

Available Options: Disabled, 3F8H/IRQ4, 2F8H/IRQ3, 3E8H/IRQ4, 2E8H/IRQ3

Default setting: 2F8H/IRQ3

UART Mode Select

The second serial port offers these infrared interface modes.

Available Options: Normal, IrDA, and ASKIR

Default setting: Normal

OnBoard Parallel Port 1

This field selects the I/O port address for parallel port.

Available Options: Disabled, 378H/IRQ7, 278H/IRQ5, 3BCH/IRQ7

Default setting: 378H/IRQ7

Parallel Port Mode

This field specifies the parallel port mode. ECP and EPP are both bi-directional data transfer schemes that adhere to the IEEE P1284 specifications.

Available Options: Printer, EPP1.7+SPP, EPP1.7+ ECP, EPP1.9, EPP, and ECP

Default setting: Printer

ECP Mode Use DMA

This field is read-only and cannot be configured.

Available Options: 0, 1, and 3

Default setting: ECP for DMA3

□ **Build In CPU Audio**

This field specifies the internal Audio Control.

Available Options: Disable, Enable

Default setting: Enable

□ **Audio Base I/O Address**

These fields select the I/O port address for Audio.

Available Options: 220H, 240H, 260H and 280H

Default setting: 220H

□ **Audio IRQ Select**

This field specifies the IRQ for the Audio.

Available Options: Disable, 5,7 and 10

Default setting: 5

□ **Audio Low DMA Select**

This field specifies the DMA for internal Audio Control.

Available Options: Disable, 0, 1 and 3

Default setting: 1

□ **Audio High DMA Select**

This field specifies the DMA for internal Audio Control.

Available Options: Disable, 5, 6 and 7

Default setting: 5

Password Setup

There are two security passwords: Supervisor and User. Supervisor is a privileged person that can change the User password from the BIOS.

According to the default setting, both access passwords are not set up and are only valid after you set the password from the BIOS.

To set the password, please complete the following steps.

1. Select **Change Supervisor Password**.
2. Type the desired password (up to 8 character length) when you see the message, "Enter New Supervisor Password."
3. Then you can go on to set a user password (up to 8 character length) if required. Note that you cannot configure the User password until the Supervisor password is set up.
4. Enter Advanced CMOS Setup screen and point to the Password Checkup field.
5. Select Always or Setup.
 - ✧ **Always:** a visitor who attempts to enter BIOS or operating system will be prompted for password.
 - ✧ **Setup:** a visitor who attempts to the operating system will be prompted for user password. You can enter either User password or Supervisor password.
6. Point to **Save Settings and Exit** and press Enter.
7. Press Y when you see the message, "Save Current Settings and Exit (Y/N)?"

Note: it is suggested that you write down the password in a safe place to avoid that password may be forgotten or missing.

To set the password, please complete the following steps.

1. Select **Change Supervisor Password**.

2. Press Enter instead of entering any character when you see the message, "Enter New Supervisor Password."
3. Thus you can disable the password.

Chapter 5 Driver and Utility

The enclosed diskette includes FB2510 VGA and LAN driver.

VGA Drivers

WIN98/WIN95 Driver

- 1 To install the VGA driver, insert the CD ROM into the CD ROM device, and enter DRIVER>VGA>NS5530>WIN98. If your system is not equipped with a CD ROM device, copy the VGA driver from the CD ROM to a 1.44" diskette.
- 2 Execute CYRIM-1.exe file.
- 3 The screen shows the SETUP type. Press any key to enter the main menu.
- 4 As the setup is completed, the system will generate the message as follows.

Yes, I want to restart my computer now. Installation is done!

No, I will restart my computer later.

System must be restart then complete the installation.

- 5 In the WINDOWS98/ME, you can find the <DISPLAYL> icon located in the {CONTROL PANEL} group.
- 6 Adjust the <Resolution> and <Color>.

LAN Utility & Driver

- 1 To install the LAN utility OR driver, insert the CD ROM into the CD ROM device, and enter DRIVER>LAN>RTL8139C. If your system is not equipped with a CD ROM device, copy the LAN VGA driver from the CD ROM to a 1.44" diskette.
- 2 Execute install.exe file.

Note: In the LAN directory, a HELPM.EXE file is included to provide installation information

Watchdog Timer

This section describes how to use the Watchdog Timer, including disabled, enabled, and trigger functions.

The FB2510 is equipped with a programmable time-out period watchdog timer. You can use your own program to enable the watchdog timer. Once you have enabled the watchdog timer, the program should trigger the I/O every time before the timer times out. If your program fails to trigger or disable this timer before it times out, e.g. because of a system hang-up, it will generate a reset signal to reset the system. The time-out period can be programmed to be set from 1 to 255 seconds or minutes.

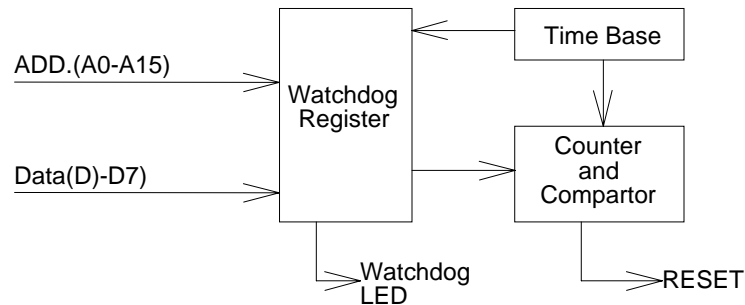

The CD-ROM includes a Watch Dog demo file. In the file, there are 3 execution programs written in different forms. The sub-directories of the file are:

1. WATCHDOG/ASSEMBLE: Library and Test Program written in Assembly Language
2. WATCHDOG/TURBOC: Library and Test Program written in Turbo C++

The WATCHDOG includes a demonstration program established for users who would like to configure the Watchdog timer by themselves.

Note: In the WATCHDOG directory, README.TXT file is included to provide demo program information.

Watchdog Timer Setting

The watchdog timer is a circuit that may be used from your program software to detect system crashes or hang-ups. LED1 on this CPU board is the watchdog timer indicator, which is located at the upper-right corner above the USB connector. Whenever the watchdog timer is enabled, the LED will blink to indicate that the timer is counting. The watchdog timer is automatically disabled after reset.

Once you have enabled the watchdog timer, your program must trigger the watchdog timer every time before it times out. After you trigger the watchdog timer, it will be set to non-zero value to watchdog counter and start to count down again. If your program fails to trigger the watchdog timer before time-out, it will generate a reset pulse to reset the system.

The factor of the watchdog timer time-out constant is approximately 1 seconds. The period for the watchdog timer time-out is between 1 to FF timer factors.

If you want to reset your system when watchdog times out, the following table listed the relation of timer factors between time-out periods.

Time Factor	Time-Out Period (Seconds)	Time-Out Period (Minutes)
1	1	1
2	2	2
3	3	3
4	4	4
5	5	5
"	"	"
"	"	"
"	"	"
FF	FF	FF

Watchdog Timer Enabled

To enable the watchdog timer, you have to output a byte of timer factor to the watchdog. The following is a Turbo C++ program, which demonstrates how to enable the watchdog timer and set the time-out period at 6 seconds.

```
#include "stdio.H"
#include "WDLIB.H"

main()
{
char WD_TIME=0x6;

InitWD(equWdUnitS);
printf ("Enable watchdog");
//Trigger watchdog Timer Output is 6 seconds
EnWD(WD_TIME);
}
```

Watchdog Timer Trigger

After you enable the watchdog timer, your program must write the same factor as enabling to the watchdog register at least once every time-out period to its previous setting. You can change the time-out period by writing another timer factor to the watchdog register at any time, and you must trigger the watchdog before the new time-out period in the next trigger. Below is a Turbo C++ program, which demonstrates how to trigger the watchdog timer:

```
#include "stdio.H"
#include "WDLIB.H"

main()
{
char WD_TIME=0x6;

InitWD(equWdUnitS);
printf ("Enable watchdog");
//Trigger watchdog Timer Output is 6 seconds
EnWD(WD_TIME);
}
```

Watchdog Timer Disabled

To disable the watchdog timer, simply write a 00H to the watchdog register.

```
#include "stdio.H"
#include "WDLIB.H"

main()
{
  InitWD(equWdUnitS);
  printf ("Disable Watch Dog");
  //Disable watch dog
  DisWD(WD_TIME);
}
```

Appendix

Dimension

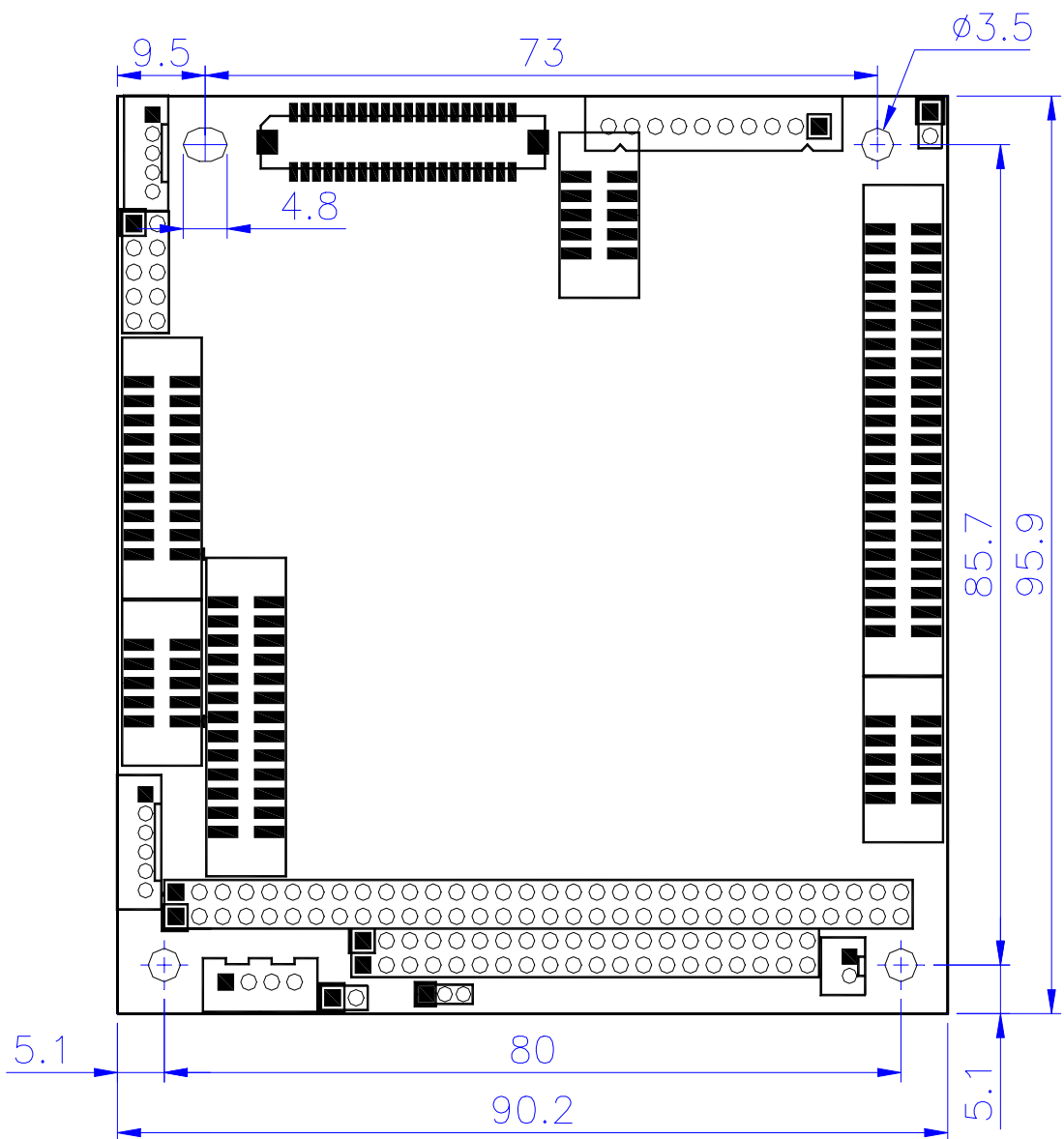

Technical Reference

Real-Time Clock and Non-Volatile RAM

The FB2510 contains a real-time clock compartment that maintains the date and time in addition to storing configuration information about the computer system. It contains 14 bytes of clock and control registers and 114 bytes of general purpose RAM. Because of the use of CMOS technology, it consumes very little power and can be maintained for long periods of time using an internal Lithium battery. The contents of each byte in the CMOS RAM are listed below:

Address	Description
00	Seconds
01	Second alarm
02	Minutes
03	Minute alarm
04	Hours
05	Hour alarm
06	Day of week
07	Date of month
08	Month
09	Year
0A	Status register A
0B	Status register B
0C	Status register C
0D	Status register D
0E	Diagnostic status byte
0F	Shutdown status byte
10	Diskette drive type byte, drive A and B
11	Fixed disk type byte, drive C
12	Fixed disk type byte, drive D
13	Reserved
14	Equipment byte
15	Low base memory byte
16	High base memory byte
17	Low expansion memory byte

Address	Description
18	High expansion memory byte
19-2D	Reserved
2E-2F	2-byte CMOS checksum
30	Low actual expansion memory byte
31	High actual expansion memory byte
32	Date century byte
33	Information flags (set during power on)
34-7F	Reserved for system BIOS

CMOS RAM Map

Register	Description
00h -10h	Standard AT-compatible RTC and Status and Status Register data definitions
11h – 13h	Varies
14h	<p>Equipment</p> <p>Bits 7-6 Number of Floppy Drives 00 1 Drive 01 2 Drives</p> <p>Bits 5-4 Monitor Type 00 Not CGA or MDA 01 40x25 CGA 01 2 Drives 80x25 CGA</p> <p>Bits 3 Display Enabled 0 Disabled 1 Enabled</p> <p>Bit 2 Keyboard Enabled 00 Not CGA or MDA 01 40x25 CGA 01 2 Drives 80x25 CGA</p> <p>Bit 1 Math Coprocessor Installed 0 Absent 1 Present</p> <p>Bit 0 Floppy Drive Installed 0 Disabled 1 Enabled</p>
15h	Base Memory (in 1KB increments), Low Byte
16h	Base Memory (in 1KB increments), High Byte
17h	IBM-compatible memory (in 1KB increments), Low Byte
18h	IBM-compatible memory (in 1KB increments), High Byte (max 15 MB)
19h-2Dh	Varies
2Eh	Standard CMOS RAM checksum, high byte
2Fh	Standard CMOS RAM checksum, low byte
30h	IBM-compatible Extended Memory, Low Byte (POST) in KB
31h	IBM-compatible Extended Memory, High Byte (POST) in KB
32h	Century Byte
33h	Reserved. Do not use
34h	Reserved. Do not use
35h	Low byte of extended memory (POST) in 64 KB
36h	High byte of extended memory (POST) in 64 KB
37h-3Dh	Varies
3Eh	Extended CMOS Checksum, Low Byte (including 34h-3Dh)
3Fh	Extended CMOS Checksum, High Byte (including 34h-3Dh)

I/O Port Address Map

Each peripheral device in the system is assigned a set of I/O port addresses, which also becomes the identity of the device. There is a total of 1K-port address space available. The following table lists the I/O port addresses used on the Industrial CPU Card.

Address	Device Description
000h - 01Fh	DMA Controller #1
020h - 03Fh	Interrupt Controller #1
040h - 05Fh	Timer
060h - 06Fh	Keyboard Controller
070h - 071h	Real Time Clock, NMI
080h - 09Fh	DMA Page Register
0A0h - 0BFh	Interrupt Controller #2
0C0h - 0DFh	DMA Controller #2
0F0h	Clear Math Coprocessor Busy Signal
0F1h	Reset Math Coprocessor
1F0h - 1F7h	IDE Interface
2E8h - 2Efh	Serial Port #4(COM4)
2F8h - 2FFh	Serial Port #2(COM2)
2B0h - 2DFh	Graphics adapter Controller
378h - 3FFh	Parallel Port #1(LPT1)
360h - 36Fh	Network Ports
3B0h - 3DFh	VGA & Printer adapter
3F0h - 3F7h	Floppy Disk Controller
3F8h - 3FFh	Serial Port #1(COM1)
480h - 48Fh	PCI Bus
4D0h - 4DFh	PCI Bus
CF8h - CFFh	PCI Bus
E000h -E0FEh	Ethernet Controller
F000h -F00Eh	IDE Controller

Interrupt Request Lines (IRQ)

There are a total of 15 IRQ lines available on the Industrial CPU Card. Peripheral devices use interrupt request lines to notify CPU for the service required. The following table shows the IRQ used by the devices on the Industrial CPU Card.

Level	Function
IRQ0	System Timer Output
IRQ1	Keyboard
IRQ2	Interrupt Cascade
IRQ3	Serial Port #2
IRQ4	Serial Port #1
IRQ5	Reserved
IRQ6	Floppy Disk Controller
IRQ7	Parallel Port #1
IRQ8	Real Time Clock
IRQ9	Reserved
IRQ10	Reserved
IRQ11	Ethernet
IRQ12	PS2-Mouse
IRQ13	FPU
IRQ14	Primary IDE
IRQ15	USB

DMA Channel Map

The equivalent of two 8237A DMA controllers are implemented in the FB2510 board. Each controller is a four-channel DMA device that will generate the memory addresses and control signals necessary to transfer information directly between a peripheral device and memory. This allows high speed information transfer with less CPU intervention. The two DMA controllers are internally cascaded to provide four DMA channels for transfers to 8-bit peripherals (DMA1) and three channels for transfers to 16-bit peripherals (DMA2). DMA2 channel 0 provides the cascade interconnection between the two DMA devices, thereby maintaining IBM PC/AT compatibility.

The following is the system information of DMA channels:

DMA Controller 1	DMA Controller 2
Channel 0: Spare	Channel 4: Cascade for controller 1
Channel 1: Reserved for IBM SDLC	Channel 5: Spare
Channel 2: Diskette adapter	Channel 6: Spare
Channel 3: Spare	Channel 7: Spare

Serial Ports

The ACEs (Asynchronous Communication Elements ACE1 to ACE4) are used to convert parallel data to a serial format on the transmit side and convert serial data to parallel on the receiver side. The serial format, in order of transmission and reception, is a start bit, followed by five to eight data bits, a parity bit (if programmed) and one, one and half (five-bit format only) or two stop bits. The ACEs are capable of handling divisors of 1 to 65535, and produce a 16x clock for driving the internal transmitter logic.

Provisions are also included to use this 16x clock to drive the receiver logic. Also included in the ACE is a completed MODEM control capability, and a processor interrupt system that may be software tailored to the computing time required to handle the communications link.

The following table is a summary of each ACE accessible register

DLAB	Port Address	Register
0	Base + 0	Receiver buffer (read)
		Transmitter holding register (write)
0	Base + 1	Interrupt enable
X	Base + 2	Interrupt identification (read only)
X	Base + 3	Line control
X	Base + 4	MODEM control
X	Base + 5	Line status
X	Base + 6	MODEM status
X	Base + 7	Scratched register
1	Base + 0	Divisor latch (least significant byte)
1	Base + 1	Divisor latch (most significant byte)

□ **Receiver Buffer Register (RBR)**

Bit 0-7: Received data byte (Read Only)

□ **Transmitter Holding Register (THR)**

Bit 0-7: Transmitter holding data byte (Write Only)

□ **Interrupt Enable Register (IER)**

Bit 0: Enable Received Data Available Interrupt (ERBFI)

Bit 1: Enable Transmitter Holding Empty Interrupt (ETBEI)

Bit 2: Enable Receiver Line Status Interrupt (ELSI)

Bit 3: Enable MODEM Status Interrupt (EDSSI)

Bit 4: Must be 0

Bit 5: Must be 0

Bit 6: Must be 0

Bit 7: Must be 0

□ **Interrupt Identification Register (IIR)**

Bit 0: "0" if Interrupt Pending

Bit 1: Interrupt ID Bit 0

Bit 2: Interrupt ID Bit 1

Bit 3: Must be 0

Bit 4: Must be 0

Bit 5: Must be 0

Bit 6: Must be 0

Bit 7: Must be 0

□ **Line Control Register (LCR)**

Bit 0: Word Length Select Bit 0 (WLS0)

Bit 1: Word Length Select Bit 1 (WLS1)

WLS1	WLS0	Word Length
0	0	5 Bits
0	1	6 Bits
1	0	7 Bits
1	1	8 Bits

Bit 2: Number of Stop Bit (STB)

Bit 3: Parity Enable (PEN)

Bit 4: Even Parity Select (EPS)

Bit 5: Stick Parity

Bit 6: Set Break

Bit 7: Divisor Latch Access Bit (DLAB)

□ **MODEM Control Register (MCR)**

Bit 0: Data Terminal Ready (DTR)

Bit 1: Request to Send (RTS)

Bit 2: Out 1 (OUT 1)

Bit 3: Out 2 (OUT 2)

Bit 4: Loop

Bit 5: Must be 0

Bit 6: Must be 0

Bit 7: Must be 0

□ **Line Status Register (LSR)**

Bit 0: Data Ready (DR)

Bit 1: Overrun Error (OR)

Bit 2: Parity Error (PE)

Bit 3: Framing Error (FE)

Bit 4: Break Interrupt (BI)

Bit 5: Transmitter Holding Register Empty (THRE)

Bit 6: Transmitter Shift Register Empty (TSRE)

Bit 7: Must be 0

□ **MODEM Status Register (MSR)**

Bit 0: Delta Clear to Send (DCTS)

Bit 1: Delta Data Set Ready (DDSR)

Bit 2: Training Edge Ring Indicator (TERI)

Bit 3: Delta Receive Line Signal Detect (DSLSD)

Bit 4: Clear to Send (CTS)

Bit 5: Data Set Ready (DSR)

Bit 6: Ring Indicator (RI)

Bit 7: Received Line Signal Detect (RSLD)

□ **Divisor Latch (LS, MS)**

	LS	MS
Bit 0:	Bit 0	Bit 8
Bit 1:	Bit 1	Bit 9
Bit 2:	Bit 2	Bit 10
Bit 3:	Bit 3	Bit 11
Bit 4:	Bit 4	Bit 12
Bit 5:	Bit 5	Bit 13
Bit 6:	Bit 6	Bit 14
Bit 7:	Bit 7	Bit 15

Desired Baud Rate	Divisor Used to Generate 16x Clock
300	384
600	192
1200	96
1800	64
2400	48
3600	32
4800	24
9600	12
14400	8
19200	6
28800	4
38400	3
57600	2
115200	1

Parallel Ports

□ **Register Address**

Port Address	Read/Write	Register
Base + 0	Write	Output data
Base + 0	Read	Input data
Base + 1	Read	Printer status buffer
Base + 2	Write	Printer control latch

□ **Printer Interface Logic**

The parallel portion of the SMC37C669 makes the attachment of various devices that accept eight bits of parallel data at standard TTL level.

□ **Data Swapper**

The system microprocessor can read the contents of the printer's Data Latch through the Data Swapper by reading the Data Swapper address

□ **Printer Status Buffer**

The system microprocessor can read the printer status by reading the address of the Printer Status Buffer. The bit definitions are described below:

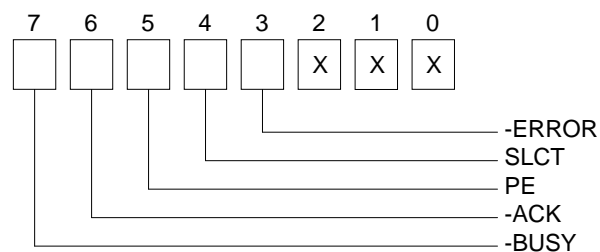

NOTE: X represents not used.

- Bit 7: This signal may become active during data entry, when the printer is off-line during printing, or when the print head is changing position or in an error state. When Bit 7 is active, the printer is busy and cannot accept data.

- Bit 6: This bit represents the current state of the printer's ACK signal. A 0 means the printer has received the character and is ready to accept another. Normally, this signal will be active for approximately 5 microseconds before receiving a BUSY message stops.

- Bit 5: A 1 means the printer has detected the end of the paper.

- Bit 4: A 1 means the printer is selected.

- Bit 3: A 0 means the printer has encountered an error condition.

□ **Printer Control Latch & Printer Control Swapper**

The system microprocessor can read the contents of the printer control latch by reading the address of printer control swapper. Bit definitions are as follows:

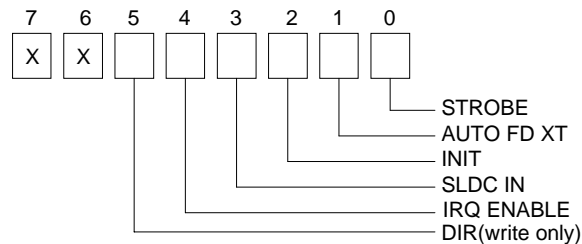

NOTE: X represents not used.

- Bit 5: Direction control bit. When logic 1, the output buffers in the parallel port are disabled allowing data driven from external sources to be read; when logic 0, they work as a printer port. This bit is write-only.

- Bit 4: A 1 in this position allows an interrupt to occur when ACK changes from low state to high state.

- Bit 3: A 1 in this bit position selects the printer.

- Bit 2: A 0 starts the printer (50 microseconds pulse, minimum).

- Bit 1: A 1 causes the printer to line-feed after a line is printed.

- Bit 0: A 0.5 microsecond minimum highly active pulse clocks data into the printer. Valid data must be present for a minimum of 0.5 microseconds before and after the strobe pulse.